

TO: BOARD OF DIRECTORS

FROM: MARIO IGLESIAS
GENERAL MANAGER



DATE: APRIL 3, 2020

AGENDA ITEM

C

APRIL 8, 2020

PRESENTATIONS AND REPORTS

The following presentations and reports are scheduled:

- C-1) QUARTERLY ENGINEER'S REPORT- DIRECTOR OF ENGINEERING AND OPERATIONS REPORT ON DISTRICT PROJECTS SYSTEM-WIDE [RECOMMEND RECEIVE AND FILE]
- C-2) DIRECTORS' ANNOUNCEMENTS OF DISTRICT AND COMMUNITY INTEREST AND REPORTS ON ATTENDANCE AT PUBLIC MEETINGS, TRAINING PROGRAMS, CONFERENCES AND SEMINARS.
Receive Announcements and Reports from Directors
- C-3) RECEIVE PUBLIC COMMENT ON PRESENTATIONS AND REPORTS PRESENTED UNDER ITEM C AND BY MOTION RECEIVE AND FILE PRESENTATIONS AND REPORTS

TO: BOARD OF DIRECTORS

FROM: MARIO E. IGLESIAS
GENERAL MANAGER



DATE: APRIL 3, 2020

AGENDA ITEM

C-1

APRIL 8, 2020

**QUARTERLY ENGINEER'S REPORT
DIRECTOR OF ENGINEERING AND OPERATIONS REPORT
ON DISTRICT PROJECTS SYSTEM-WIDE**

ITEM

Engineering and Operations update for January through March 2020

BACKGROUND

Director of Engineering and Operations, Peter Sevcik will overview his update (Attachment A) and discuss District projects for the January through March 2020 period.

RECOMMENDATION

Staff recommends that your Honorable Board receive the update.

ATTACHMENTS

- A. Engineering and Operations Update for January to March 2020

APRIL 8, 2020

ITEM C-1

ATTACHMENT A

Engineering and Operations Update – January to March 2020

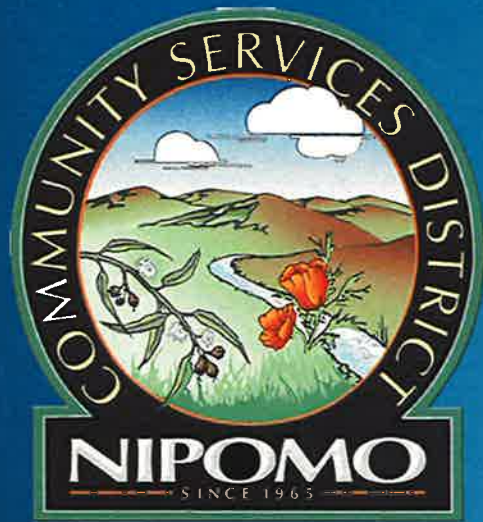

Peter V. Sevcik, P.E.
Director of Engineering and Operations
Nipomo Community Services District
April 8, 2020



COVID-19 Response Current Status

- Following CDC social distancing guidance
- Staff working staggered schedules
- Focused on essential water and wastewater operations
- Continuing with critical construction projects
 - Nipomo Supplemental Water Project Nipomo Area Pipeline Improvements
 - Southland WWTF Storage Building
 - Eureka Well
 - Southland WWTF Screw Press



COVID-19 Response Preparations

- Securing on-site housing for critical operations staff, if need to sequester staff on-site arises
- Monitoring inventory and availability of critical services and supplies
- Monitoring ability to continue critical construction projects

Projects in Construction

Supplemental Water Project Nipomo Area Pipeline Improvements

- Construction in Progress
- Billed to date - \$238,864
- Tentative Completion Date - October 2020
- Contract Cost - \$2,902,107



Projects in Construction

Southland WWTF Storage Building

- Construction in Progress
- Billed to date - \$0
- Tentative Completion Date – August 2020
- Contract Cost - \$175,000

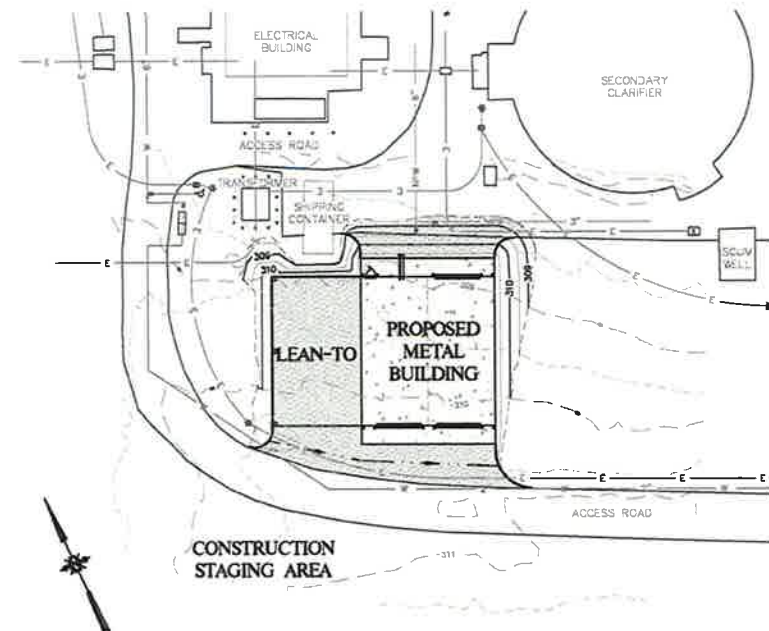

Projects in Construction

Eureka Well Replacement

- Bid date – January 2020
- Board bid award – March 11, 2020
- Notice to proceed – Pending
- Tentative Completion Date – August 2020
- Contract Cost – \$738,678

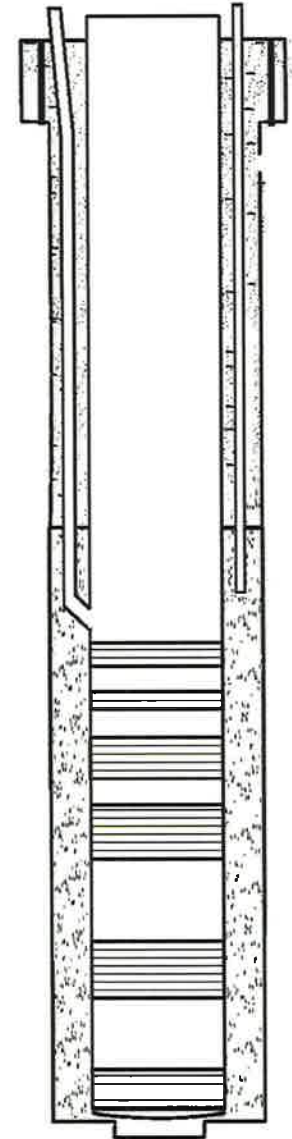

Projects in Bid Phase

Southland WWTF Screw Press

- Bids opened –
March 26, 2020
- Tentative Board bid
award – May 13, 2020
- Budgeted Construction
Cost - \$920,000

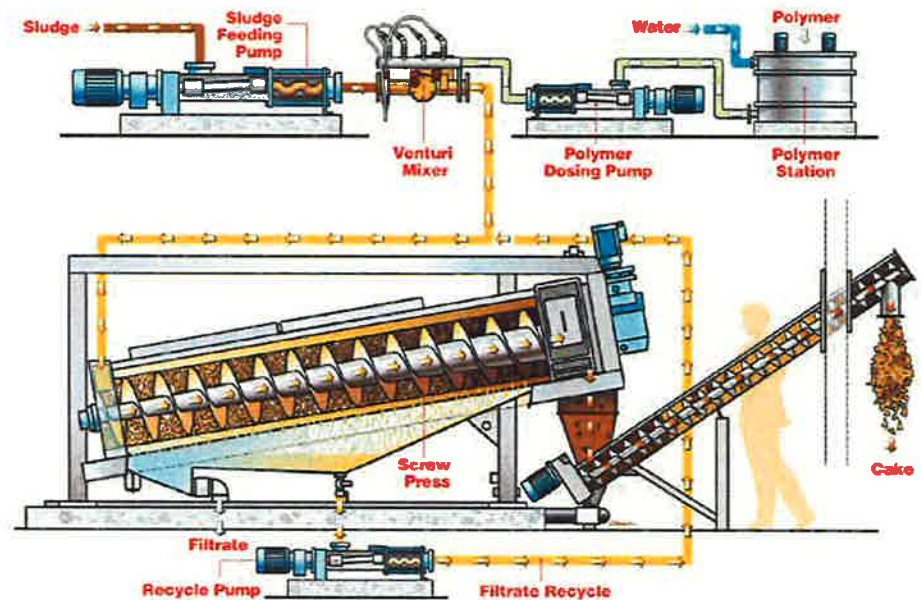

Operations – Water System

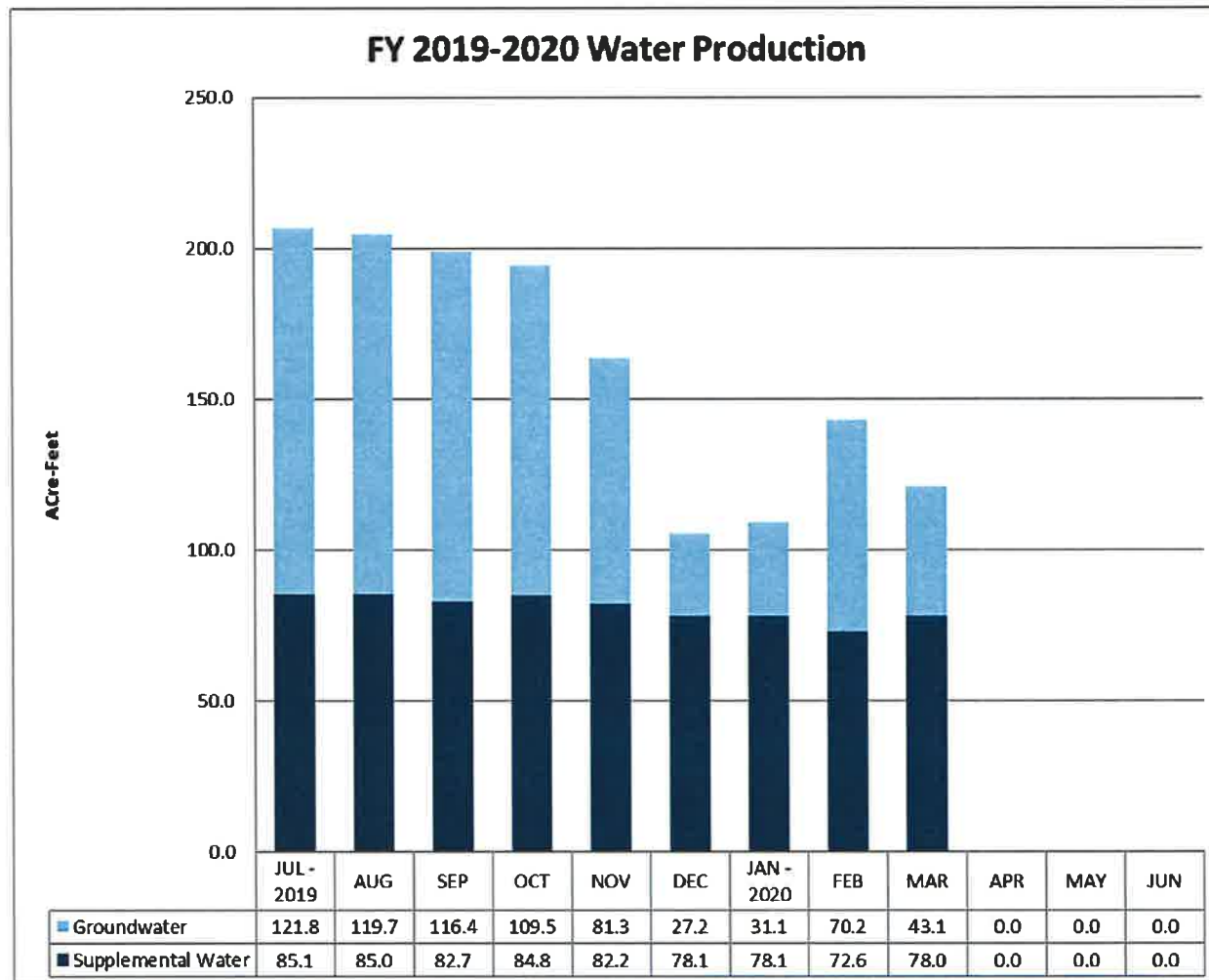

Supplemental Water	727 AF
Groundwater	720 AF
FY 19-20 Total Production To Date	1447 AF

Operations – Wastewater

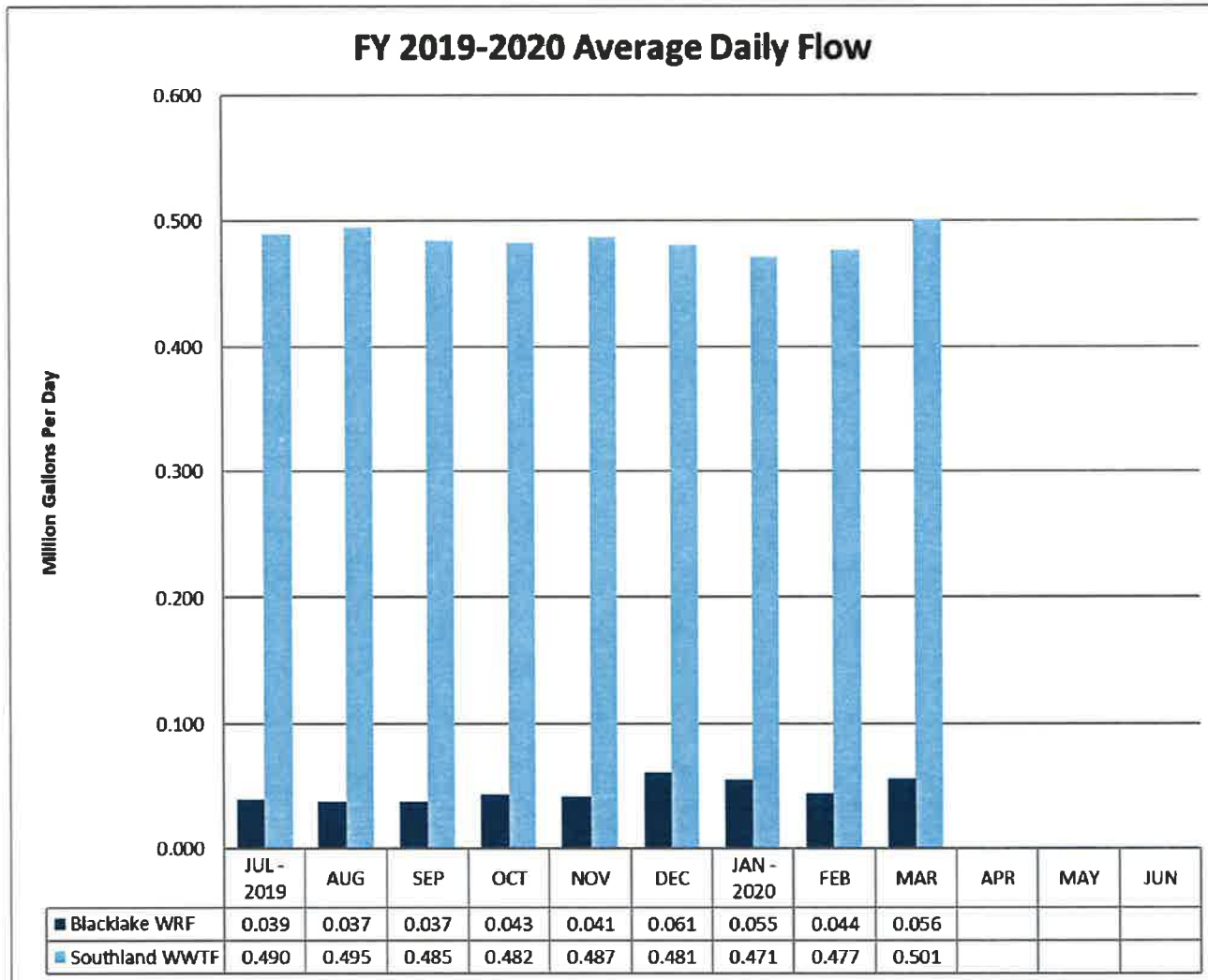

Blacklake WRF	12.7 MG
Southland WWTF	133.5 MG
FY 19-20 Total Wastewater Flow Treated To Date	146.2 MG or 449 AF



Engineering and Operations

Questions

TO: BOARD OF DIRECTORS

FROM: MARIO IGLESIAS
GENERAL MANAGER



DATE: APRIL 3, 2020

AGENDA ITEM

D

APRIL 8, 2020

CONSENT AGENDA

The following items are considered routine and non-controversial by staff and may be approved by one motion if no member of the Board wishes an item removed. If discussion is desired, the item may be removed from the Consent Agenda by a Board member and will be considered separately at the conclusion of the Administrative Items. Individual items on the Consent Agenda are approved by the same vote that approves the Consent Agenda, unless an item is pulled for separate consideration. The recommendations for each item are noted in bracket. Members of the public may comment on the Consent Agenda items.

**Questions or clarification may be made by the Board members
without removal from the Consent Agenda.**

- D-1) WARRANTS [RECOMMEND APPROVAL]
- D-2) APPROVE MARCH 24, 2020, SPECIAL BOARD MEETING MINUTES
[RECOMMEND APPROVE MINUTES]
- D-3) ADOPT RESOLUTION AMENDING THE NEWSPAPERS OF GENERAL
CIRCULATION AND PUBLICATION REQUIREMENTS FOR PUBLICATION OF
DISTRICT BUSINESS [RECOMMEND ADOPT RESOLUTION]
- D-4) INITIATE PROCEEDINGS FOR ANNUAL LEVY OF ASSESSMENTS FOR STREET
LANDSCAPE MAINTENANCE DISTRICT NO. 1 [RECOMMEND ADOPT
RESOLUTION]

TO: BOARD OF DIRECTORS

REVIEWED: MARIO IGLESIAS ~~MI~~
GENERAL MANAGER

FROM: LISA BOGNUDA LSB
FINANCE DIRECTOR

DATE: APRIL 3, 2020

AGENDA ITEM
D-1
APRIL 8, 2020

WARRANTS

TOTAL COMPUTER CHECKS
\$258,324.11

HANDWRITTEN CHECKS

20492	03-25-20	GET AWAY RV RENTALS	2 TRAILER RENTALS	\$3,400.00
-------	----------	---------------------	-------------------	------------

VOIDS – NONE

COMPUTER GENERATED CHECKS – SEE ATTACHED



Nipomo Community Services District

Item D-1 Warrants APRIL 8, 2020

By Payment Number

Payment Dates 04/01/2020 - 04/08/2020

Vendor Name	Description (Payable)	Payable Number	Payment Date	Amount
Payment: 5872				
Get Away RV Rentals	2 trailer rentals	INV0006650	04/01/2020	4,000.00
				Payment 5872 Total:
				<u>4,000.00</u>
Payment: 5873				
Abalone Coast Analytical, Inc.	Lab tests	4907	04/08/2020	6,434.70
				Payment 5873 Total:
				<u>6,434.70</u>
Payment: 5874				
Alexander's Contract Services,	Meter reading	202003300872	04/08/2020	2,482.00
				Payment 5874 Total:
				<u>2,482.00</u>
Payment: 5875				
American Industrial Supply	Galvanized floor flange	0341939	04/08/2020	17.19
				Payment 5875 Total:
				<u>17.19</u>
Payment: 5876				
Applied Technology Group, In	SCADA upgrades	19235	04/08/2020	788.19
Applied Technology Group, In	SCADA upgrade	19330	04/08/2020	3,037.35
				Payment 5876 Total:
				<u>3,825.54</u>
Payment: 5877				
AT&T	Telephone	14505024	04/08/2020	242.57
AT&T	Telephone	14505023	04/08/2020	165.06
AT&T	Telephone	14505022	04/08/2020	29.06
				Payment 5877 Total:
				<u>436.69</u>
Payment: 5878				
Bill Gaines Audio, Inc.	Blacklake Sewer	INV-02157	04/08/2020	1,318.80
				Payment 5878 Total:
				<u>1,318.80</u>
Payment: 5879				
Brenntag Pacific, Inc.	Sodium hypochlorite	32804	04/08/2020	162.14
				Payment 5879 Total:
				<u>162.14</u>
Payment: 5880				
California Highway Patrol	Collision report - Avenida de	MAR2020	04/08/2020	10.00
				Payment 5880 Total:
				<u>10.00</u>
Payment: 5881				
California Water Environment	Membership renewal - Germa	MAR2020	04/08/2020	192.00
				Payment 5881 Total:
				<u>192.00</u>
Payment: 5882				
CalPortland Construction	Truck rental	94539536	04/08/2020	158.40
CalPortland Construction	Class 2 base	94539537	04/08/2020	522.76
				Payment 5882 Total:
				<u>681.16</u>
Payment: 5883				
Charter Communications	Internet - Shop and/or Office	0224495032020	04/08/2020	734.20
Charter Communications	Internet - Shop and/or Office	0225708032220	04/08/2020	734.20
				Payment 5883 Total:
				<u>1,468.40</u>
Payment: 5884				
Clever Ducks	Computer expense - VPN lice	28449	04/08/2020	900.00
				Payment 5884 Total:
				<u>900.00</u>
Payment: 5885				
EMCOR Services Mesa Energy	Service call - SWWTP	013546001	04/08/2020	397.82
				Payment 5885 Total:
				<u>397.82</u>
Payment: 5886				
Excel Personnel Services, Inc.	Employment agency	2992393	04/08/2020	930.00
Excel Personnel Services, Inc.	Background check	51062	04/08/2020	24.50

Item D-1 Warrants APRIL 8, 2020

Payment Dates: 04/01/2020 - 04/08/2020

Vendor Name	Description (Payable)	Payable Number	Payment Date	Amount
Excel Personnel Services, Inc.	Employment agency	2996867	04/08/2020	465.00
Payment: 5886 Total:				1,419.50
Payment: 5887				
Famcon Pipe and Supply, Inc.	Meter boxes	5100025118.001	04/08/2020	674.25
Payment: 5887 Total:				674.25
Payment: 5888				
FedEx	Package handling	6-970-20763	04/08/2020	47.62
Payment: 5888 Total:				47.62
Payment: 5889				
FGL Environmental	Lab tests	080577	04/08/2020	521.00
Payment: 5889 Total:				521.00
Payment: 5890				
GLM Landscape Management	Landscape maintenance	MAR2020	04/08/2020	405.00
Payment: 5890 Total:				405.00
Payment: 5891				
Great Western Alarm and Co	Alarm monitoring service	200302107101	04/08/2020	70.00
Great Western Alarm and Co	Alarm monitoring service	200300640101	04/08/2020	37.00
Great Western Alarm and Co	Alarm monitoring service	200302062101	04/08/2020	70.00
Payment: 5891 Total:				177.00
Payment: 5892				
Home Depot Credit Services D	Broom, shovels	MAR2020	04/08/2020	280.38
Payment: 5892 Total:				280.38
Payment: 5893				
Integrated Industrial Supply, I	Disposable gloves	68112	04/08/2020	338.48
Integrated Industrial Supply, I	Shop towels	68146	04/08/2020	120.12
Payment: 5893 Total:				458.60
Payment: 5894				
Miner's Ace Hardware	Supplies	FEB2020	04/08/2020	978.56
Payment: 5894 Total:				978.56
Payment: 5895				
Mission Uniform Service	Uniforms	512101271	04/08/2020	161.53
Mission Uniform Service	Uniforms	512150335	04/08/2020	149.09
Payment: 5895 Total:				310.62
Payment: 5896				
MNS Engineers, Inc.	Construction management - P	74795	04/08/2020	38,134.73
Payment: 5896 Total:				38,134.73
Payment: 5897				
Office Depot	Office supplies	462077533001	04/08/2020	401.02
Office Depot	Office supplies	465313525001	04/08/2020	140.50
Office Depot	Office supplies	460769922001	04/08/2020	105.08
Payment: 5897 Total:				646.60
Payment: 5898				
PG&E	Contract # 50021010 V1	115710963	04/08/2020	2,254.79
Payment: 5898 Total:				2,254.79
Payment: 5899				
Polydyne, Inc.	Clarifloc	1441107	04/08/2020	163.18
Payment: 5899 Total:				163.18
Payment: 5900				
Powerstride Battery Co., Inc.	Batteries	83656	04/08/2020	301.28
Powerstride Battery Co., Inc.	Batteries	83674	04/08/2020	18.86
Payment: 5900 Total:				320.14
Payment: 5901				
Praxair Distribution, Inc.	Cylinder rental	95642199	04/08/2020	49.82
Payment: 5901 Total:				49.82

Item D-1 Warrants APRIL 8, 2020

Payment Dates: 04/01/2020 - 04/08/2020

Vendor Name	Description (Payable)	Payable Number	Payment Date	Amount
Payment: 5902				
R. Baker, Inc.	Progress payment #2	1502-2	04/08/2020	170,949.13
Payment 5902 Total:				170,949.13
Payment: 5903				
Santa Maria Ford Lincoln	Vehicle repair/maintenance	190021	04/08/2020	2,201.69
Santa Maria Ford Lincoln	Vehicle repair/maintenance	190508	04/08/2020	71.08
Santa Maria Ford Lincoln	Vehicle repair/maintenance	190213	04/08/2020	779.33
Payment 5903 Total:				3,052.10
Payment: 5904				
SoCalGas	Heat - shop/office	MAR2020B	04/08/2020	52.81
Payment 5904 Total:				52.81
Payment: 5905				
South County Sanitary Service	Solid waste tax liens	MAR2020	04/08/2020	629.75
Payment 5905 Total:				629.75
Payment: 5906				
Terminix Commercial	Pest control	395011031	04/08/2020	54.00
Payment 5906 Total:				54.00
Payment: 5907				
Tesco Controls, Inc.	SCADA troubleshoot/modifica	0069873	04/08/2020	4,132.50
Payment 5907 Total:				4,132.50
Payment: 5908				
Tuckfield & Associates	Water Financial Plan	0580	04/08/2020	1,159.39
Payment 5908 Total:				1,159.39
Payment: 5909				
United Rentals	Boom rental	180059553-001	04/08/2020	762.80
Payment 5909 Total:				762.80
Payment: 5910				
US Bank National Association	Travel and meals	MAR2020B	04/08/2020	570.55
US Bank National Association	Software subscription	MAR2020D	04/08/2020	50.97
US Bank National Association	Blacklake outreach	MAR2020C	04/08/2020	463.05
US Bank National Association	Operating supplies	MAR2020E	04/08/2020	163.11
US Bank National Association	Storage unit	MAR2020A	04/08/2020	199.50
Payment 5910 Total:				1,447.18
Payment: 5911				
USA Bluebook	CHEMKEYS	181168	04/08/2020	3,208.76
USA Bluebook	Hypalon liner	183367	04/08/2020	131.96
USA Bluebook	Pump tubes, tube housing cov	181004	04/08/2020	239.89
USA Bluebook	Hand sanitizer	188014	04/08/2020	341.91
Payment 5911 Total:				3,922.52
Payment: 5912				
Verizon Wireless	Cell service	9851094134	04/08/2020	643.13
Payment 5912 Total:				643.13
Payment: 5913				
Wallace Group	FOG program	50430	04/08/2020	1,820.20
Payment 5913 Total:				1,820.20
Payment: 5914				
Waste Connections	Waste collection - Olde Towne	6820160	04/08/2020	255.91
Waste Connections	Waste collection - Southland	6820536	04/08/2020	226.20
Waste Connections	Waste collection - Office	6819224	04/08/2020	48.26
Payment 5914 Total:				530.37

TO: BOARD OF DIRECTORS

FROM: MARIO IGLESIAS
GENERAL MANAGER

DATE: APRIL 3, 2020

AGENDA ITEM
D-2
APRIL 8, 2020

**APPROVE MARCH 24, 2020
SPECIAL BOARD MEETING MINUTES**

ITEM

Approve action minutes from previous Board meetings. [RECOMMEND APPROVE MINUTES]

BACKGROUND

The draft minutes are a written record of the previous Board Meeting action.

RECOMMENDATION

Approve Minutes

ATTACHMENT

- A. March 24, 2020 draft Special Board Meeting Minutes

APRIL 8, 2020

ITEM D-2

ATTACHMENT A

NIPOMO COMMUNITY SERVICES DISTRICT

Serving the Community since 1965

DRAFT SPECIAL MEETING MINUTES

MARCH 24, 2020 AT 2:00 P.M.

JON S. SEITZ BOARD ROOM 148 SOUTH WILSON STREET, NIPOMO, CA

BOARD of DIRECTORS

DAN ALLEN GADDIS, PRESIDENT
CRAIG ARMSTRONG, VICE PRESIDENT
BOB BLAIR, DIRECTOR
ED EBY, DIRECTOR
DAN WOODSON, DIRECTOR

PRINCIPAL STAFF

MARIO IGLESIAS, GENERAL MANAGER
LISA BOGNUDA, FINANCE DIRECTOR
CRAIG A. STEELE, GENERAL COUNSEL
PETER SEVCIK, DIRECTOR OF ENG. & OPS.

Mission Statement:

Provide our customers with reliable, quality, and cost-effective services now and in the future.

Pursuant to Governor Newsom's Executive Order N-25-20, members of the Nipomo Community Services District or staff may participate in this meeting via teleconference. Members of the public may participate in the meeting telephonically by calling (800) 567-5900 (code 242-2614# or in person at 148 South Wilson Street, Nipomo CA where seating designed to maintain appropriate social distancing will be provided. Alternately, members of the public may comment on items on this agenda via email sent to info@ncsd.ca.gov prior to the time the meeting starts.

1. CALL TO ORDER AND FLAG SALUTE

President Gaddis called the Special Meeting of March 24, 2020, to order at 2:02 p.m. and led the flag salute.

2. ROLL CALL AND PUBLIC COMMENT FOR ITEMS ON AGENDA

At Roll Call, Director Gaddis, Eby and Blair were present in the Board Room. Director Woodson and Director Armstrong were present telephonically.

There were no public comments. (There were no members of the public present at the meeting and there were no members of the public participating telephonically). No emails were received at the info@ncsd.ca.gov address prior to the time the meeting started.

3. PRESENTATIONS AND REPORTS

A) NIPOMO COMMUNITY SERVICES DISTRICT RESPONSE TO COVID-19 PANDEMIC [RECOMMEND RECEIVE AND FILE]

Mario Iglesias, General Manager, presented the Power Point presentation regarding District actions to manage an efficient and effective response to COVID-19 pandemic and answered questions from the Board.

There were no public comments.

Receive Announcements and Reports from Directors

Director Gaddis

- *March 15, attended Board Officers' meeting.*
- *March 20, attended a conference call on COVID-19 update related to District operations.*

SUBJECT TO BOARD APPROVAL

Nipomo Community Services District
DRAFT SPECIAL MEETING
MINUTES

*Upon the motion of Director Eby and seconded, the Board unanimously approved receiving and filing presentations and reports.
Vote 5-0.*

YES VOTES	NO VOTES	ABSENT
Directors, Eby, Blair, Woodson, Armstrong and Gaddis	None	None

4. CONSENT AGENDA

D-1) WARRANTS [RECOMMEND APPROVAL]

D-2) APPROVE MARCH 11, 2020, REGULAR BOARD MEETING MINUTES
[RECOMMEND APPROVE MINUTES]

There were no public comments.

*Upon the motion of Director Eby and seconded, the Board unanimously approved the Consent Agenda.
Vote 5-0.*

YES VOTES	NO VOTES	ABSENT
Directors, Eby, Blair, Woodson, Armstrong and Gaddis	None	None

5. ADMINISTRATIVE ITEMS

E-1) DECLARATION OF EMERGENCY AND RESOLUTION OF THE BOARD OF DIRECTORS OF THE NIPOMO COMMUNITY SERVICES DISTRICT TO TEMPORARILY AUTHORIZE ADDITIONAL SPECIFIED AUTHORITY FOR THE GENERAL MANAGER {RECOMMEND ADOPT RESOLUTION}

Craig Steele, District Legal Counsel, presented the item and answered questions from the Board.

Directors Gaddis, Woodson and Eby requested amendments to items, 2, 3 and 7 in the Resolution.

*Upon the motion of Director Eby and seconded, the Board unanimously approved the Resolution, as amended.
Vote 5-0.*

YES VOTES	NO VOTES	ABSENT
Directors Eby, Blair, Woodson, Armstrong and Gaddis	None	None

Resolution No. 2020-1550

A RESOLUTION OF THE BOARD OF DIRECTORS OF THE NIPOMO COMMUNITY SERVICES DISTRICT DECLARING AN EMERGENCY AND TO TEMPORARILY AUTHORIZE ADDITIONAL SPECIFIED AUTHORITY FOR THE GENERAL MANAGER

SUBJECT TO BOARD APPROVAL

**Nipomo Community Services District
DRAFT SPECIAL MEETING
MINUTES**

The Regular Board meeting of March 25, 2020 is cancelled.

The next Regular Board Meeting will be Wednesday, April 8, 2020 at 9:00 a.m.

ADJOURN MEETING

President Gaddis adjourned the meeting at 2:44 p.m.

MEETING SUMMARY	HOURS & MINUTES
Special Meeting	0 hour 42 minutes
Closed Session	0 hour 00 minutes
TOTAL HOURS	0 hour 42 minutes

Respectfully submitted,

Mario Iglesias, General Manager and Secretary to the Board

Date

TO: BOARD OF DIRECTORS
FROM: MARIO IGLESIAS
GENERAL MANAGER 
DATE: APRIL 3, 2020



PUBLICATION OF PUBLIC NOTICE IN NEWSPAPERS

ITEM

Consider amending the Nipomo Community Services District ("District") policy for publishing notices in newspapers meeting the requirements of Government Code Section 6008 to include New Times [RECOMMEND ADOPT RESOLUTION EXPANDING PUBLICATION POLICY]

BACKGROUND

The District is required to post public notice for a variety of District actions and/or proposed actions in local newspapers. Currently, the District has within its publication policy, Resolution 2012-1274, two local newspapers that meet the requirements in Government Code Section 6008 for publishing public notices.

Staff is recommending your Board expand the publishing policy and include New Times. New Times has been adjudged as a newspaper of general circulation by the Superior Court of San Luis Obispo, and therefore meets the requirements for publishing public notices.

By including New Times in the District's publication policy, staff has additional flexibility for publishing in a timely and more cost competitive manner.

FISCAL IMPACT

The typical cost of publishing notices in the Santa Maria Times is \$100 - \$700 depending on the required form of publication. Publication in the Tribune typically costs 20-40% more than in the Santa Maria Times and 50- 60% more than New Times.

STRATEGIC PLAN

Goal 6. GOVERNANCE AND ADMINISTRATION. Conduct District activities in an efficient, equitable and cost-effective manner.

- A.1 Periodically review, update and reaffirm District policies and procedures.

RECOMMENDATION

It is recommended that your Board adopt the attached resolution amending the District's publication policy.

ATTACHMENTS

- A. Resolution 2020-XXXX, Amending the Newspaper of General Circulation and Publication Requirement

APRIL 8, 2020

ITEM D-3

ATTACHMENT A

**NIPOMO COMMUNITY SERVICES DISTRICT
RESOLUTION 2020-_____**

**A RESOLUTION OF THE BOARD OF DIRECTORS
OF THE NIPOMO COMMUNITY SERVICES DISTRICT
AMENDING THE NEWSPAPERS OF GENERAL CIRCULATION AND PUBLICATION
REQUIREMENTS FOR PUBLICATION OF DISTRICT BUSINESS**

WHEREAS, the Nipomo Community Services District ("District") periodically publishes legal notifications in the newspaper, including but not limited to, notices of public hearings, notice of inviting bids and adopted ordinances; and

WHEREAS, the District periodically publishes general advertisements in the newspaper, including but not limited to, employment openings and notifications of upcoming events; and

WHEREAS, pursuant to Government Code Section 6008, legal notifications must be published in a newspaper of general circulation that is published not less than weekly and is distributed to paid subscribers; and

WHEREAS, the Santa Maria Times has been adjudged as a newspaper of general circulation by the Superior Court of the County of Santa Barbara, Case #46386; and

WHEREAS, the Tribune has been adjudged as a newspaper of general circulation by the Superior Court of the County of San Luis Obispo, Case #19139; and

WHEREAS, the New Times has been adjudged as a newspaper of general circulation by the Superior Court of the County of San Luis Obispo, Case #CV072789.

NOW, THEREFORE, BE IT RESOLVED, DETERMINED, AND ORDERED by the Board of Directors of the Nipomo Community Services District, San Luis Obispo County, California, as follows:

1. Except as otherwise directed by the Board of Directors, at the discretion of the General Manager or designee, all District legal notices shall be published in either the Santa Maria Times, the Tribune, or the New Times, provided publishing deadlines can be met by that newspaper.
2. The above Recitals are true and correct and incorporated herein by this reference.

**NIPOMO COMMUNITY SERVICES DISTRICT
RESOLUTION 2020-_____**

**A RESOLUTION OF THE BOARD OF DIRECTORS
OF THE NIPOMO COMMUNITY SERVICES DISTRICT
AMENDING THE NEWSPAPERS OF GENERAL CIRCULATION AND PUBLICATION
REQUIREMENTS FOR PUBLICATION OF DISTRICT BUSINESS**

Upon the motion of Director _____, seconded by Director _____, and on the following roll call vote, to wit:

**AYES:
NOES:
ABSENT:
CONFLICTS:**

The foregoing resolution is hereby adopted this ____ day of April, 2020.

DAN ALLEN GADDIS
President of the Board

ATTEST:

APPROVED AS TO FORM:

MARIO IGLESIAS
General Manager and Secretary to the Board

CRAIG A. STEELE
District Legal Counsel

TO: BOARD OF DIRECTORS
FROM: MARIO IGLESIAS
GENERAL MANAGER 
DATE: APRIL 3, 2020

AGENDA ITEM
D-4
APRIL 8, 2020

**INITIATE PROCEEDINGS FOR ANNUAL LEVY OF ASSESSMENTS
FOR STREET LANDSCAPE MAINTENANCE DISTRICT NO. 1**

ITEM

Resolution initiating proceedings for annual levy of Street Landscape Maintenance District No. 1 ("LMD #1) [RECOMMEND ADOPT RESOLUTION]

BACKGROUND

In 2003, the Board of Directors formed Street Landscape Maintenance District No. 1 to provide the street landscape maintenance for Tract 2409 (Sculpture Homes located on Vista Verde and Ida Street). The LMD formed under Government Code Section 61601.20 and the Landscaping and Lighting Act of 1972.

Annually, the District follows the procedures outlined in the Government Code and Prop. 218 to levy the assessment on each of the 28 property owners served by the Landscape Maintenance District. In order to proceed, the attached Resolution should be adopted to initiate the proceedings and appoint Director of Engineering and Operations, Peter Sevcik as the Assessment Engineer.

RECOMMENDATION

Staff recommends adopting the attached resolution initiating proceedings for annual assessment of LMD #1.

ATTACHMENT

- A. Resolution No. 2020-XXXX LMD Initiate Proceedings for Annual Assessment

APRIL 8, 2020

ITEM D-4

ATTACHMENT A

**NIPOMO COMMUNITY SERVICES DISTRICT
RESOLUTION NO. 2020-XXXX**

**A RESOLUTION OF THE BOARD OF DIRECTORS OF THE
NIPOMO COMMUNITY SERVICES DISTRICT INITIATING PROCEEDINGS FOR ANNUAL
LEVY OF ASSESSMENTS FOR THE STREET LANDSCAPE MAINTENANCE DISTRICT NO. 1
FOR FISCAL YEAR 2020-2021 PURSUANT TO THE PROVISIONS OF PART 2 OF
DIVISION 15 OF THE CALIFORNIA STREETS AND HIGHWAYS CODE**

WHEREAS, the Nipomo Community Services District Board of Directors (“NCS D”) has, by previous Petition and Resolution, formed the Nipomo Community Services District Street Landscape Maintenance District No. 1 (hereinafter referred to as “Street Landscape Maintenance District No. 1”) pursuant to the provisions of Government Code §61122 (prior §61601.20) and the Landscaping and Lighting Act of 1972 (hereinafter referred to as the “Act”) that provides for the levy and collection of assessments by the County of San Luis Obispo for the Nipomo Community Services District to pay for the installation, planting and maintenance of landscaping within public streets, right of ways or easements within the Nipomo Community Services District; and

WHEREAS, Street Landscape Maintenance District No. 1 and the associated assessments are in compliance with the provisions of California Constitution Article XIII D; and

WHEREAS, the NCS D has appointed Peter Sevcik, a registered professional engineer, as assessment engineer for the purpose of assisting with the Annual Levy of the Street Landscape Maintenance District No. 1 and to prepare and file a report in accordance with the Act.

NOW, THEREFORE BE IT RESOLVED, DETERMINED, AND ORDERED by the Board of Directors of the Nipomo Community Services District for the Nipomo Street Landscape Maintenance District No. 1, as follows:

SECTION 1: The NCS D hereby initiates proceedings for annual levy of assessments for Street Landscape Maintenance District No. 1 for Fiscal Year 2020-2021 pursuant to the provisions of the Act.

SECTION 2: The improvements within Street Landscape Maintenance District No. 1 include: trees, shrubs, grass, other ornamental vegetation, and appurtenant facilities, including irrigation system within the Street Landscape Maintenance District No. 1. The Board of Directors does not anticipate new improvements or substantial changes in existing improvements.

SECTION 3: Engineer’s Annual Levy Report: The NCS D Board of Directors hereby orders that Peter Sevcik, District Director of Engineering and Operations and a registered professional engineer in CA, prepare the Engineer’s Annual Levy Report concerning the levy of assessments for Street Landscape Maintenance District No. 1 in accordance with *Chapter 3, Section 22622* of the Act.

Upon the motion of Director _____, seconded by Director _____, and on the following roll call vote, to wit:

**AYES:
NOES:
ABSENT:
CONFLICTS:**

the foregoing resolution is hereby adopted this _____ day of April 2020.

DAN ALLEN GADDIS
President of the Board

ATTEST:

APPROVED AS TO FORM
AND LEGAL EFFECT:

MARIO IGLESIAS
General Manager and Secretary to the Board

CRAIG A. STEELE
District Legal Counsel