

TO: BOARD OF DIRECTORS

FROM: MARIO E. IGLESIAS
GENERAL MANAGER



DATE: JANUARY 16, 2020



**QUARTERLY ENGINEER'S REPORT
DIRECTOR OF ENGINEERING AND OPERATIONS REPORT
ON DISTRICT PROJECTS SYSTEM-WIDE**

ITEM

Engineering and Operations update for October through December 2019

BACKGROUND

Director of Engineering and Operations, Peter Sevcik will overview his update (Attachment A) and discuss District projects for the October through December 2019 period.

RECOMMENDATION

Staff recommends that your Honorable Board receive the update.

ATTACHMENTS

- A. Engineering and Operations Update for October to December 2019

JANUARY 22, 2020

ITEM C-1

ATTACHMENT A

Engineering and Operations Update – October to December 2019



Peter V. Sevcik, P.E.
Director of Engineering and Operations
Nipomo Community Services District
January 22, 2020

Projects in Construction

Supplemental Water Project Nipomo Area Pipeline Improvements

- Board Awarded – December 11, 2019
- Notice to Proceed – Pending
- Tentative Completion Date – October 2020
- Contract Cost - \$2,902,107



Projects in Construction

Southland WWTF Storage Building

- Board Awarded – December 11, 2019
- Notice to Proceed – Pending
- Tentative Completion Date – August 2020
- Contract Cost - \$175,000

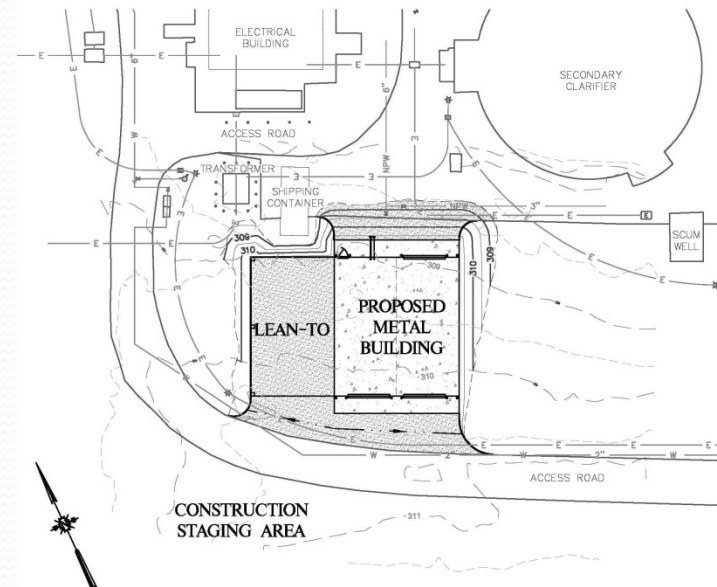

Projects in Bid Phase

Eureka Well Replacement

- Existing Eureka Well destroyed
- Board authorization to bid – December 11, 2019
- Final bid documents – District review pending
- Tentative bid date – January 2020
- Tentative Board bid award – March 2020
- Budgeted project cost – \$1,000,000

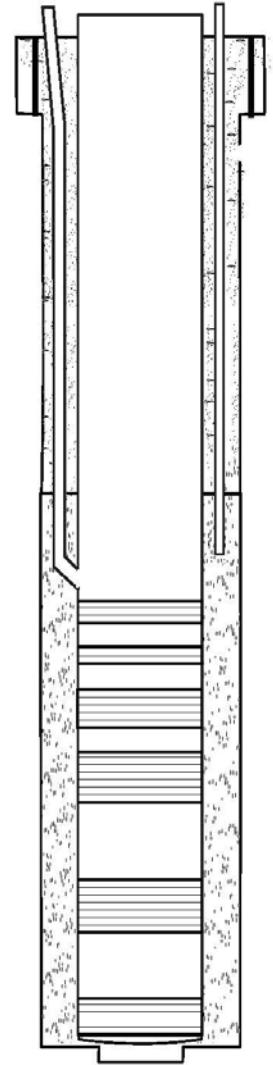

Projects in Bid Phase

Southland WWTF Screw Press

- Board authorization to bid – December 11, 2019
- Final bid documents – Pending
- Tentative bid date – February 2020
- Tentative Board bid award – April 2020
- Budgeted Construction Cost – \$920,000

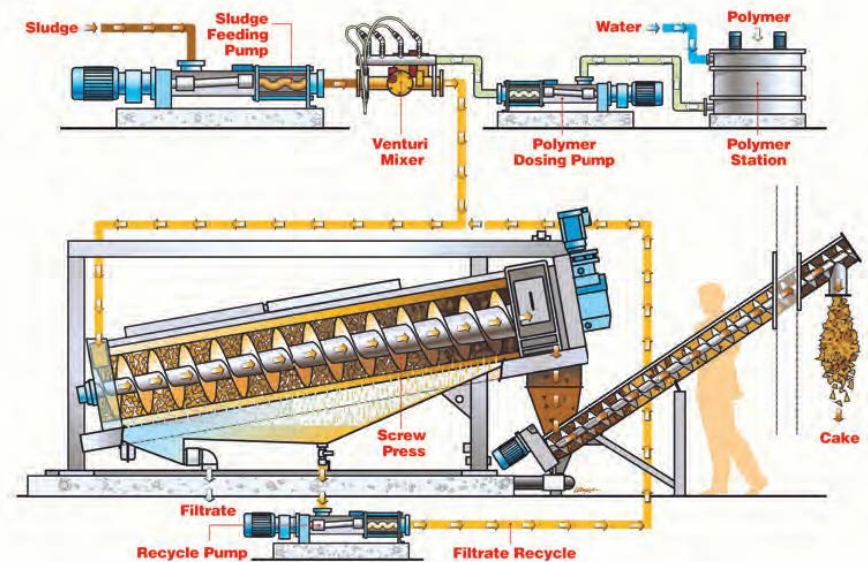

Projects in Design

Supplemental Water Project Joshua Road Pump Station Improvements

- 100% Design pending
- Tentative Board authorization to bid – February 2020
- Tentative Bid Date – March 2020
- Tentative Board bid award – May 2020



Projects in Design

Supplemental Water Project Interconnects

- 95% Design pending
- Need to acquire easement from Woodlands Mutual Water Company
- Draft Mitigated Negative Declaration circulated for public comment
- Tentative Board authorization to bid – February 2020
- Tentative Board award – June 2020

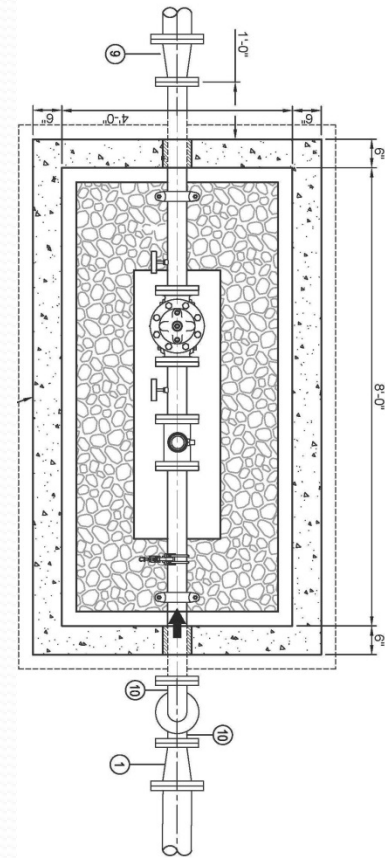

Projects in Design

Nipomo Palms Lift Station Replacement

- 100% design pending
- Tentative Board authorization to bid – June 2020
- Tentative Board bid award – August 2020

Woodgreen Lift Station Replacement

- 50% design plans pending
- Tentative Board authorization to bid– June 2020
- Tentative Board bid award – August 2020

Operations – Water System

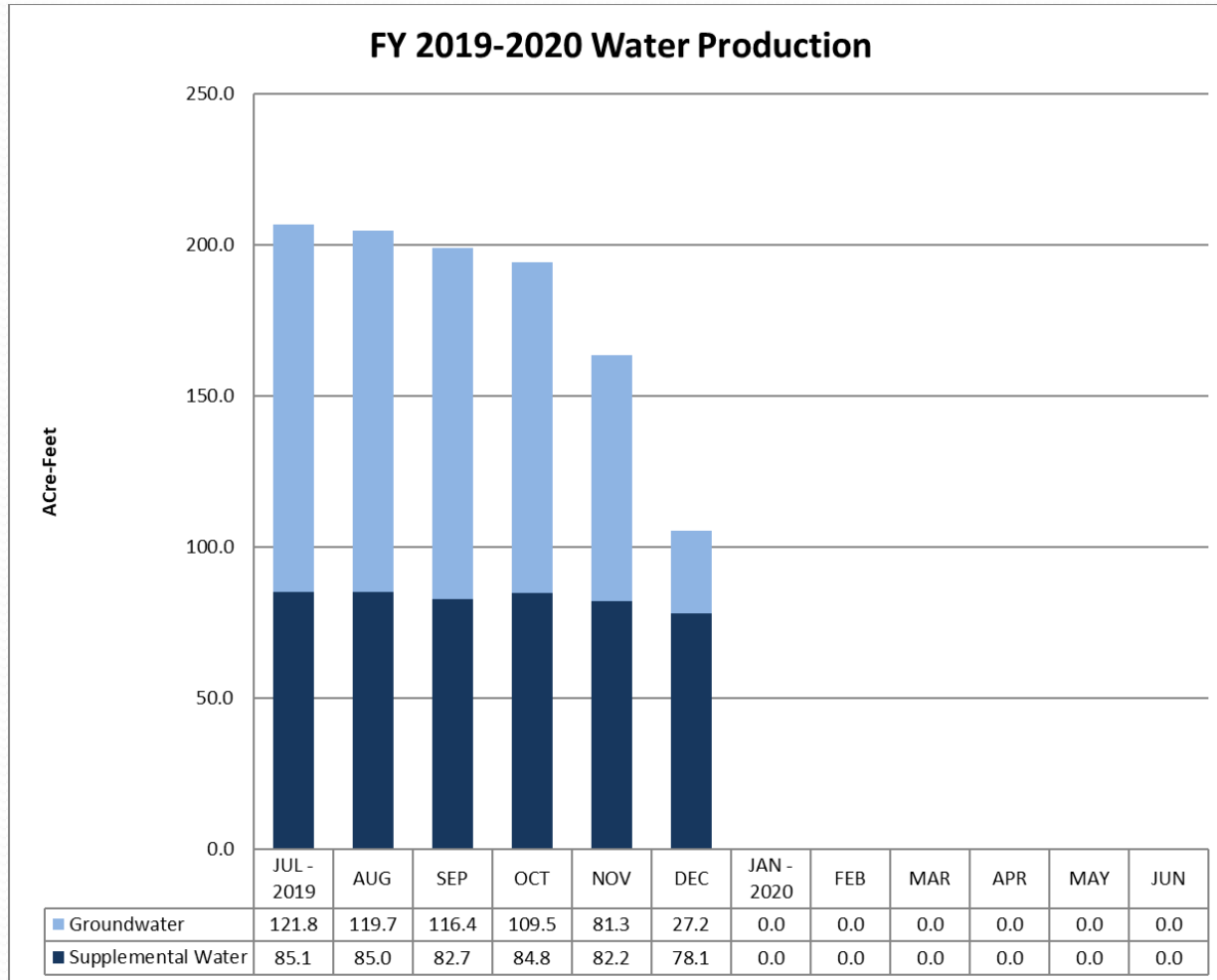

Supplemental Water	498 AF
Groundwater	576 AF
FY 19-20 Total Production To Date	1074 AF

Operations – Water System

- **State Water Resources Control Board Division of Drinking Water**
 - Submitted routine monthly coliform, quarterly raw water coliform, quarterly nitrate, quarterly disinfection byproducts, and annual asbestos reports
 - UCMR₄ fifth round completed October 2019
- **Other Water Operations**
 - Replaced hydrant in Blacklake
 - Annual electrical system preventive maintenance
 - JRPS VFD#₄ connected to Pump #₃

Operations – Wastewater

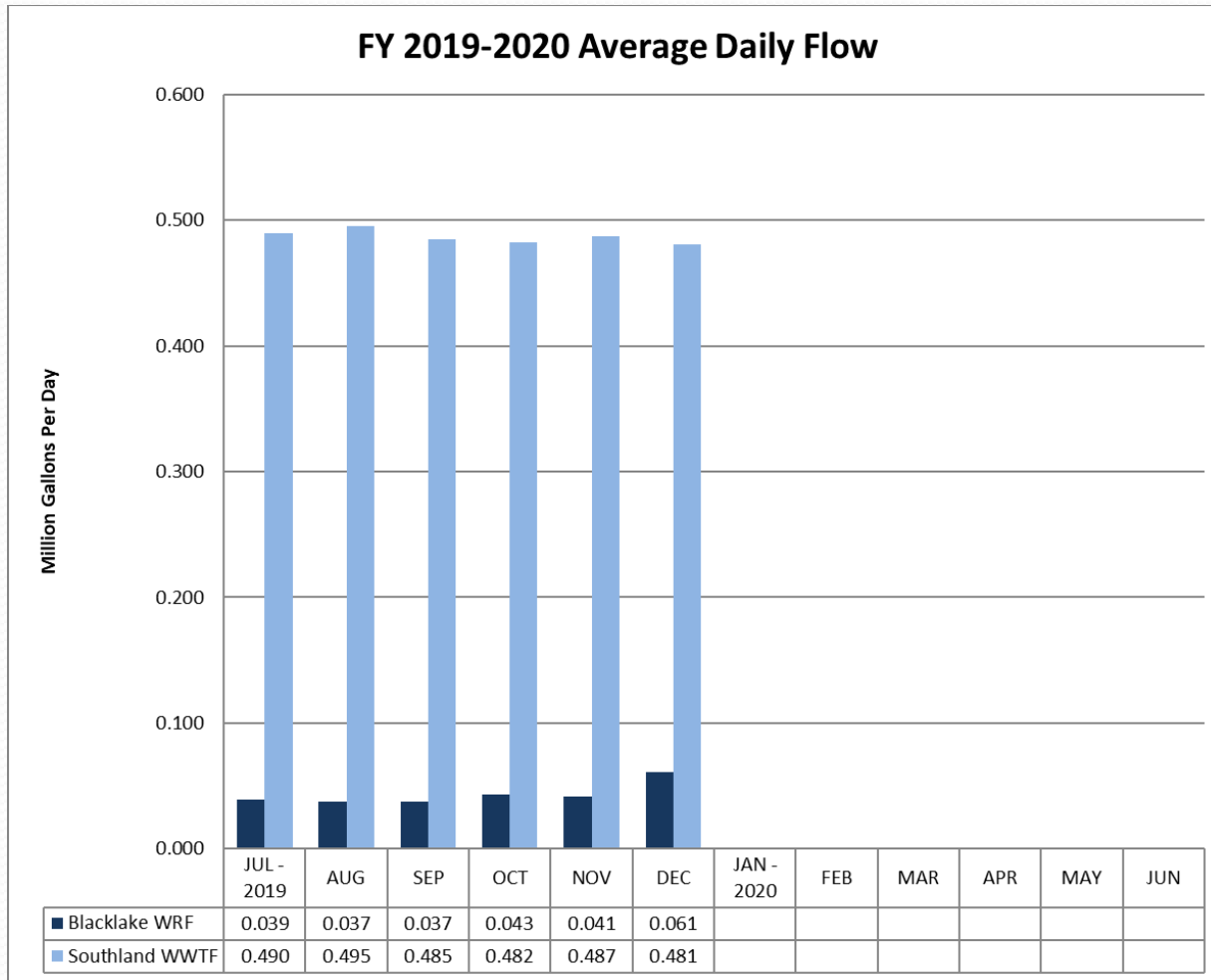

Blacklake WRF	7.9 MG
Southland WWTF	89.6 MG
FY 19-20 Total Wastewater Flow Treated To Date	97.5 MG or 299 AF

Operations – Wastewater System

- **State Water Resources Control Board**
 - Routine monthly and quarterly reports submitted
 - Sewer spill from Tejas Lift Station force main air release valve
- **Other Wastewater Operations**
 - Annual electrical system preventive maintenance
 - Removed accumulated sludge at Blacklake WRF
 - Received replacement RAS pump for Southland WWTF
 - Installed new antenna pole at Juniper LS
 - Installed site light at Maria Vista LS

Other Engineering and Operations

- **Other**
 - Blacklake Sewer Consolidation
 - SCADA Radio Replacement Project
 - Well Site Operator Interface Project
- **Personnel – Safety Training**
 - Annual Hearing Test
 - Training Water Operator 1
 - Training Wastewater Operator 1

Other Engineering and Operations

- **New Development**

- CO 17-0131 – Frank Court – Single Family Residential – In construction
- Tract 2441 – Blume – Single Family Residential – In construction

Engineering and Operations

Questions

TO: BOARD OF DIRECTORS

FROM: MARIO IGLESIAS
GENERAL MANAGER 

DATE: JANUARY 17, 2020



CONSENT AGENDA

The following items are considered routine and non-controversial by staff and may be approved by one motion if no member of the Board wishes an item removed. If discussion is desired, the item may be removed from the Consent Agenda by a Board member and will be considered separately at the conclusion of the Administrative Items. Individual items on the Consent Agenda are approved by the same vote that approves the Consent Agenda, unless an item is pulled for separate consideration. The recommendations for each item are noted in bracket. Members of the public may comment on the Consent Agenda items.

**Questions or clarification may be made by the Board members
without removal from the Consent Agenda.**

- D-1) WARRANTS [RECOMMEND APPROVAL]
- D-2) APPROVE JANUARY 8, 2020, REGULAR BOARD MEETING MINUTES
[RECOMMEND APPROVE MINUTES]
- D-3) INVESTMENT POLICY – FOURTH QUARTER REPORT [RECOMMEND RECEIVE
AND FILE]

TO: BOARD OF DIRECTORS

REVIEWED: MARIO IGLESIAS
GENERAL MANAGER

~~MAI~~

FROM: LISA BOGNUDA *LSB*
FINANCE DIRECTOR

DATE: JANUARY 17, 2020

AGENDA ITEM
D-1
JANUARY 22, 2020

WARRANTS

TOTAL COMPUTER CHECKS
\$505,355.58

HANDWRITTEN CHECKS

None

VOIDS – NONE

COMPUTER GENERATED CHECKS – SEE ATTACHED



Nipomo Community Services District

Item D-1 Warrants JANUARY 22, 2020
By Payment Number

Payment Dates 01/22/2020 - 01/22/2020

Vendor Name	Description (Payable)	Payable Number	Payment Date	Amount
Payment: 5635				
Advantage Answering Plus, In	Answering service	15-800-791	01/22/2020	266.40
Payment 5635 Total:				<u>266.40</u>
Payment: 5636				
Allweather Landscape Mainte	LMD	36765	01/22/2020	325.00
Payment 5636 Total:				<u>325.00</u>
Payment: 5637				
Brenntag Pacific, Inc.	Sodium Hypochlorite	BPI13729	01/22/2020	703.39
Brenntag Pacific, Inc.	Sodium Hypochlorite	BPI10727	01/22/2020	561.03
Brenntag Pacific, Inc.	Sodium Hypochlorite	BPI12030	01/22/2020	721.43
Payment 5637 Total:				<u>1,985.85</u>
Payment: 5638				
Cal-Coast Machinery, Inc.	Rods, bushings	583699	01/22/2020	14.68
Cal-Coast Machinery, Inc.	Bushing kit, hitch quick coupl	581962	01/22/2020	669.78
Cal-Coast Machinery, Inc.	Quick coupler parts exchange	584214	01/22/2020	-214.79
Cal-Coast Machinery, Inc.	Bushings	583954	01/22/2020	20.65
Payment 5638 Total:				<u>490.32</u>
Payment: 5639				
Clever Ducks	Computer expense	28046	01/22/2020	2,535.00
Payment 5639 Total:				<u>2,535.00</u>
Payment: 5640				
Electricraft, Inc.	Wire pump #3 to VFD	16123	01/22/2020	2,901.75
Payment 5640 Total:				<u>2,901.75</u>
Payment: 5641				
Engel & Gray, Inc.	Biosolids collection	9CX00009	01/22/2020	5,335.30
Payment 5641 Total:				<u>5,335.30</u>
Payment: 5642				
Everywhere Right Now, Inc	Computer expense	2444	01/22/2020	2,350.00
Payment 5642 Total:				<u>2,350.00</u>
Payment: 5643				
Excel Personnel Services, Inc.	Employment agency	2946173	01/22/2020	372.00
Excel Personnel Services, Inc.	Employment agency	2941840	01/22/2020	93.00
Payment 5643 Total:				<u>465.00</u>
Payment: 5644				
Farm Supply Company	Hunter Node	71402	01/22/2020	188.11
Farm Supply Company	Hunter Node	67449	01/22/2020	94.93
Farm Supply Company	Cat Litter Absorb	67776	01/22/2020	156.47
Payment 5644 Total:				<u>439.51</u>
Payment: 5645				
FGL Environmental	Lab tests	984156A	01/22/2020	521.00
Payment 5645 Total:				<u>521.00</u>
Payment: 5646				
Iconix Waterworks (US) Inc.	Grate	17913054671	01/22/2020	244.69
Payment 5646 Total:				<u>244.69</u>
Payment: 5647				
Iglesias, Mario	Cell phone reimbursement	JAN2020	01/22/2020	65.00
Payment 5647 Total:				<u>65.00</u>
Payment: 5648				
Integrated Industrial Supply, I	Disposable gloves	66195	01/22/2020	225.65
Payment 5648 Total:				<u>225.65</u>

Item D-1 Warrants JANUARY 22, 2020

Payment Dates: 01/22/2020 - 01/22/2020

Vendor Name	Description (Payable)	Payable Number	Payment Date	Amount
Payment: 5649				
Jan-Pro Central Coast	Janitorial services	87342	01/22/2020	727.14
Payment 5649 Total:				727.14
Payment: 5650				
M&M Backflow and Meter M	Meter testing	000823	01/22/2020	1,317.50
M&M Backflow and Meter M	Meter testing	829	01/22/2020	375.00
Payment 5650 Total:				1,692.50
Payment: 5651				
Mission Uniform Service	Uniforms	511561683	01/22/2020	146.21
Mission Uniform Service	Uniforms	511608978	01/22/2020	146.21
Payment 5651 Total:				292.42
Payment: 5652				
NexTraq	GPS subscription	AT01480775	01/22/2020	479.40
Payment 5652 Total:				479.40
Payment: 5653				
Nipomo Community Services	805 Alta Vista - domestic	JAN2020B	01/22/2020	23.26
Nipomo Community Services	BLWWTF	JAN2020D	01/22/2020	74.19
Nipomo Community Services	SWWTP	JAN2020E	01/22/2020	41.49
Nipomo Community Services	805 Alta Vista - landscape	JAN2020A	01/22/2020	23.26
Nipomo Community Services	LMD	JAN2020C	01/22/2020	94.11
Nipomo Community Services	Juniper LS	JAN2020F	01/22/2020	28.71
Payment 5653 Total:				285.02
Payment: 5654				
Nu-Tech Pest Management	Pest control	0148446	01/22/2020	265.00
Nu-Tech Pest Management	Rodent control	0148447	01/22/2020	75.00
Payment 5654 Total:				340.00
Payment: 5655				
Office Depot	Office supplies	425178666001	01/22/2020	99.16
Payment 5655 Total:				99.16
Payment: 5656				
PG&E	Electricity	JAN2020	01/22/2020	34,180.98
Payment 5656 Total:				34,180.98
Payment: 5657				
Praxair Distribution, Inc.	Cylinder	9382308	01/22/2020	51.10
Payment 5657 Total:				51.10
Payment: 5658				
Pryor Learning Solutions, Inc.	Training renewal - Cahua	JAN2020A	01/22/2020	199.00
Payment 5658 Total:				199.00
Payment: 5659				
Quinn Company	Concrete	PC910055008	01/22/2020	295.35
Quinn Company	Concrete	PC910055142	01/22/2020	339.17
Payment 5659 Total:				634.52
Payment: 5660				
Ray Morgan Company	Copier maintenance	2819104	01/22/2020	845.33
Ray Morgan Company	B&W/Color copies	2822978	01/22/2020	206.30
Ray Morgan Company	B&W/Color copies	2822977	01/22/2020	85.76
Payment 5660 Total:				1,137.39
Payment: 5661				
ReadyRefresh by Nestle	Distilled water	09L0900023136	01/22/2020	30.75
Payment 5661 Total:				30.75
Payment: 5662				
Richards, Watson & Gershon	Water Rights Adjudication	225115	01/22/2020	5,277.22
Payment 5662 Total:				5,277.22
Payment: 5663				
Richards, Watson & Gershon	Legal services thru 12-31-19	225114	01/22/2020	8,043.00

Item D-1 Warrants JANUARY 22, 2020

Payment Dates: 01/22/2020 - 01/22/2020

Vendor Name	Description (Payable)	Payable Number	Payment Date	Amount
				Payment 5663 Total: <u>8,043.00</u>
Payment: 5664				
Santa Maria Sun, LLC	Conservation ads	308271	01/22/2020	396.00
Santa Maria Sun, LLC	Conservation ads	308519	01/22/2020	396.00
				Payment 5664 Total: <u>792.00</u>
Payment: 5665				
SGS Guadalupe	CAN-17	780132546	01/22/2020	458.50
				Payment 5665 Total: <u>458.50</u>
Payment: 5666				
Tesco Controls, Inc.	SCADA - JRPS	0069182	01/22/2020	11,250.00
				Payment 5666 Total: <u>11,250.00</u>
Payment: 5667				
United Rentals	Articulating boom rental	177316509-001	01/22/2020	1,230.01
United Rentals	Water truck rental	165510172-015	01/22/2020	2,567.25
				Payment 5667 Total: <u>3,797.26</u>
Payment: 5668				
USA Bluebook	CorePRO sampler, Stenner ass	093603	01/22/2020	391.48
USA Bluebook	Stenner pump tube and tubin	112288	01/22/2020	525.73
USA Bluebook	CHEMKEYS	097065	01/22/2020	407.01
USA Bluebook	Stenner index spider assembl	100934	01/22/2020	93.25
USA Bluebook	Filters, nitrite/nitrate tests	102210	01/22/2020	252.78
USA Bluebook	Pressure transmitter	099859	01/22/2020	729.25
				Payment 5668 Total: <u>2,399.50</u>
Payment: 5669				
Wallace Group	FOG program	49784	01/22/2020	1,422.45
				Payment 5669 Total: <u>1,422.45</u>
Payment: 5670				
Water Savers Irrigation Mana	Irrigation audit and tune up	2732	01/22/2020	450.00
				Payment 5670 Total: <u>450.00</u>
Payment: 5671				
Willdan Financial Services	BL Assessment Engineering Se	010-43595	01/22/2020	6,347.00
				Payment 5671 Total: <u>6,347.00</u>
Payment: 5673				
City of Santa Maria	Water purchased 10-1-19 to 1	81574	01/22/2020	406,818.80
				Payment 5673 Total: <u>406,818.80</u>

TO: BOARD OF DIRECTORS
FROM: MARIO IGLESIAS
GENERAL MANAGER 
DATE: JANUARY 17, 2020



**APPROVE JANUARY 8, 2020
REGULAR BOARD MEETING MINUTES**

ITEM

Approve action minutes from previous Board meetings. [RECOMMEND APPROVE MINUTES]

BACKGROUND

The draft minutes are a written record of the previous Board Meeting action.

RECOMMENDATION

Approve Minutes

ATTACHMENT

- A. January 8, 2020 draft Regular Board Meeting Minutes

JANUARY 22, 2020

ITEM D-2

ATTACHMENT A

NIPOMO COMMUNITY SERVICES DISTRICT

Serving the Community since 1965

DRAFT REGULAR MINUTES

JANUARY 8, 2020 AT 9:00 A.M.

JON S. SEITZ BOARD ROOM 148 SOUTH WILSON STREET, NIPOMO, CA

BOARD of DIRECTORS

DAN ALLEN GADDIS, PRESIDENT
CRAIG ARMSTRONG, VICE PRESIDENT
BOB BLAIR, DIRECTOR
ED EBY, DIRECTOR
DAN WOODSON, DIRECTOR

PRINCIPAL STAFF

MARIO IGLESIAS, GENERAL MANAGER
LISA BOGNUDA, FINANCE DIRECTOR
CRAIG A. STEELE, GENERAL COUNSEL
PETER SEVCIK, DIRECTOR OF ENG. & OPS.

Mission Statement:

Provide our customers with reliable, quality, and cost-effective services now and in the future.

A. CALL TO ORDER AND FLAG SALUTE

President Gaddis called the Regular Meeting of January 8, 2020, to order at 9:00 a.m. and led the flag salute.

B. ROLL CALL AND PUBLIC COMMENT FOR ITEMS NOT ON AGENDA

At Roll Call, all Board Members were present.

Commander Michael Manuele of the San Luis Obispo County Sheriff's Office provided a summary of Calls for Service and Reports written from the month of December for South County known as Beat 7.

C. PRESENTATIONS AND REPORTS

C-1) RECOGNITION OF 2019 BOARD OFFICERS AND SEATING 2020 BOARD OFFICERS

President Gaddis presented Director Eby with a gavel and thanked him for his service as Board President for 2018 and 2019.

There were no public comments.

C-2) 2019 FALL GROUNDWATER INDEX REVIEW [RECOMMEND RECEIVE AND FILE]

Brad Newton of Newton Geo-Hydrology Consulting Services presented the 2019 Fall Ground Water Index and answered questions from the Board.

There were no public comments.

C-3) DIRECTORS' ANNOUNCEMENTS OF DISTRICT AND COMMUNITY INTEREST AND REPORTS ON ATTENDANCE AT PUBLIC MEETINGS, TRAINING PROGRAMS, CONFERENCES AND SEMINARS.

Receive Announcements and Reports from Directors

Director Woodson

- Indicated the Dial-A-Ride program would be expanded*
- January 9, members of the California Transportation Commission would be meeting in Pismo Beach to discuss the Shell Beach Straits highway improvements.*

SUBJECT TO BOARD APPROVAL

Nipomo Community Services District
DRAFT REGULAR MEETING
MINUTES

Director Eby

- December 12, attended NMMA meeting.
- January 23, next NMMA meeting. He asked for a substitute as he will be on vacation.

C-4) RECEIVE PUBLIC COMMENT ON PRESENTATIONS AND REPORTS PRESENTED UNDER ITEM C AND BY MOTION RECEIVE AND FILE PRESENTATIONS AND REPORTS

There were no public comments.

Upon the motion of Director Eby and seconded, the Board unanimously approved receiving and filing presentations and reports.
Vote 5-0.

YES VOTES	NO VOTES	ABSENT
Directors Eby, Armstrong, Woodson, Blair and Gaddis	None	None

D. CONSENT AGENDA

- D-1) WARRANTS [RECOMMEND APPROVAL]
- D-2) APPROVE DECEMBER 11, 2019, REGULAR BOARD MEETING MINUTES [RECOMMEND APPROVE MINUTES]
- D-3) APPROVE FIRST AMENDMENT TO AGREEMENT FOR PROFESSIONAL LEGAL SERVICES-GENERAL COUNSEL [RECOMMEND APPROVAL]
- D-4) ANNUAL REVIEW OF DISTRICT CASH RESERVE POLICY [RECOMMEND REVIEW AND REAFFIRM DISTRICT CASH RESERVE POLICY]

Peter Sevcik, Director of Engineering and Operations, answered questions from the Board regarding warrant #5569.

There were no public comments.

Upon the motion of Director Armstrong and seconded, the Board unanimously approved Consent Agenda Items
Vote 5-0.

YES VOTES	NO VOTES	ABSTAIN
Directors Armstrong, Blair, Woodson, Eby and Gaddis	None	None

E. ADMINISTRATIVE ITEMS

- E-1) RATIFY 2020 BOARD COMMITTEE ASSIGNMENTS [RECOMMEND APPROVE COMMITTEE ASSIGNMENTS]

President Gaddis called for recommendations. Director Eby suggested the Chamber of Commerce be removed.

There were no public comments.

SUBJECT TO BOARD APPROVAL

**Nipomo Community Services District
DRAFT REGULAR MEETING
MINUTES**

*Upon the motion of Director Eby and seconded, the Board unanimously ratified the 2020 Committee Assignments, as amended.
Vote 5-0.*

YES VOTES	NO VOTES	ABSTAIN
<i>Directors Eby, Armstrong, Woodson, Blair and Gaddis</i>	<i>None</i>	<i>None</i>

- E-2) **ADOPT RESOLUTION REQUESTING CONSENT OF THE BOARD OF SUPERVISORS OF THE COUNTY OF SAN LUIS OBISPO TO THE FORMATION OF THE PROPOSED NCSD BLACKLAKE SEWER ASSESSMENT DISTRICT [RECOMMEND ADOPT RESOLUTION]**

Mario Iglesias, General Manager, presented the item and answered questions from the Board. Craig Steele, District Legal Counsel, answered questions from the Board.

Mr. Iglesias requested minor wording changes on Exhibit A of the project description located on page A9 in the Board Packet item.

There were no public comments.

*Upon the motion of Director Eby and seconded, the Board unanimously approved the Resolution, as amended.
Vote 5-0.*

YES VOTES	NO VOTES	ABSENT
<i>Directors Eby, Armstrong, Woodson, Blair and Gaddis</i>	<i>None</i>	<i>None</i>

RESOLUTION 2020-1537

A RESOLUTION OF THE BOARD OF DIRECTORS OF THE NIPOMO COMMUNITY SERVICES DISTRICT REQUESTING CONSENT OF THE BOARD OF SUPERVISORS OF THE COUNTY OF SAN LUIS OBISPO TO THE FORMATION OF PROPOSED NIPOMO COMMUNITY SERVICES DISTRICT ASSESSMENT DISTRICT NO. 2020-1 (BLACKLAKE SEWER CONSOLIDATION) AND THE APPROVAL OF THE PROPOSED RESOLUTION OF INTENTION THEREFORE

- E-3) **ADOPT RESOLUTION REVISING DISTRICT INVESTMENT POLICY [RECOMMEND ADOPT RESOLUTION]**

Mario Iglesias, General Manager, presented the item and answered questions from the Board.

There were no public comments.

*Upon the motion of Director Armstrong and seconded, the Board unanimously approved the Resolution.
Vote 5-0.*

YES VOTES	NO VOTES	ABSTAIN
<i>Directors Eby, Armstrong, Woodson, Blair and Gaddis</i>	<i>None</i>	<i>None</i>

RESOLUTION 2020-1538

A RESOLUTION OF THE BOARD OF DIRECTORS OF THE NIPOMO COMMUNITY SERVICES DISTRICT ADOPTING A REVISED DISTRICT INVESTMENT POLICY

SUBJECT TO BOARD APPROVAL

- E-4) REVIEW AND AMEND DEBT MANAGEMENT POLICY AND ADOPTION OF CONTINUING DISCLOSURE UNDERTAKING POLICY [RECOMMEND ADOPT RESOLUTION]
Mario Iglesias, General Manager, presented the item and answered questions from the Board.

President Gaddis requested the wording "to the best of its knowledge" be inserted into Section 1 and Section 4 of the Resolution.

There were no public comments.

Upon the motion of Director Eby and seconded, the Board unanimously approved the Resolution, as amended.

Vote 5-0.

YES VOTES	NO VOTES	ABSENT
<i>Directors Eby, Woodson, Armstrong, Blair and Gaddis</i>	<i>None</i>	<i>None</i>

RESOLUTION 2020-1539

A RESOLUTION OF THE BOARD OF DIRECTORS OF THE NIPOMO COMMUNITY SERVICES DISTRICT APPROVING THE ADOPTION OF THE AMENDMENT TO THE DEBT MANAGEMENT POLICY AND THE ADOPTION OF A CONTINUING DISCLOSURE UNDERTAKING POLICY FOR THE DISTRICT

F. GENERAL MANAGER'S REPORT

Mario Iglesias, General Manager, presented the item and answered questions from the Board.

There were no public comments.

G. COMMITTEE REPORTS

None

H. DIRECTORS' REQUESTS TO STAFF AND SUPPLEMENTAL REPORTS

None

I. CLOSED SESSION ANNOUNCEMENTS

- 1. CONFERENCE WITH DISTRICT LEGAL COUNSEL RE: PENDING LITIGATION PURSUANT TO GC §54956.9
 - a. SMVWCD V. NCSD (SANTA CLARA COUNTY CASE NO. CV 770214, SIXTH APPELLATE COURT CASE NO. H032750, AND ALL CONSOLIDATED CASES)

J. PUBLIC COMMENT ON CLOSED SESSION ITEMS

There were no public comments.

K. ADJOURN TO CLOSED SESSION

President Gaddis adjourned to Closed Session at 10:19 a.m. and called for a ten minute break.

**L. OPEN SESSION
 ANNOUNCEMENT OF REPORTABLE ACTIONS, IF ANY, TAKEN IN CLOSED SESSION**

SUBJECT TO BOARD APPROVAL

Nipomo Community Services District
DRAFT REGULAR MEETING
MINUTES

There were no public comments

Craig Steele, District Legal Counsel, announced the Board discussed Item 1 in Closed Session and took no reportable action.

ADJOURN MEETING

President Gaddis adjourned the meeting at 11:03 a.m.

MEETING SUMMARY	HOURS & MINUTES
Regular Meeting	1 hour 19 minutes
Closed Session	0 hour 44 minutes
TOTAL HOURS	2 hours 03 minutes

Respectfully submitted,

Mario Iglesias, General Manager and Secretary to the Board

Date

TO: BOARD OF DIRECTORS
 FROM: MARIO IGLESIAS
 GENERAL MANAGER *MHI*

**AGENDA ITEM
 D-3
 JANUARY 22, 2020**

DATE: JANUARY 17, 2020

INVESTMENT POLICY – FOURTH QUARTER REPORT

ITEM

Review Investment Policy Fourth Quarter Report [RECOMMEND ACCEPT AND FILE REPORT]

BACKGROUND

The District's Investment Policy requires the Finance Officer file a quarterly report that identifies the District's investments and their compliance with the policy. The quarterly report is considered by the Board of Directors and is filed with the District's auditor.

As District Finance Officer and Treasurer, I am pleased to inform the Board of Directors that the District is in compliance with the Investment Policy and that the objectives of safety, liquidity, and yield have been met. The District has the ability to meet cash flow requirements for the next six months.

INVESTMENT POLICY-FOURTH QUARTER REPORT 12/31/19

Investment	Institution	Amount of Deposit 12/31/19	Rate of Interest as of 12/31/19	Quarterly Interest Earned or Accrued 12/31/19	Amount of Deposit 12/31/18	Rate of Interest as of 12/31/18	Quarterly Interest Earned or Accrued 12/31/18
Public Checking (1)	Rabobank	\$344,950.80	n/a	n/a	\$93,270.58	n/a	n/a
Pooled Money Investment	Local Agency Investment Fund (LAIF)	\$20,678,889.59	2.29%	\$117,434.37	\$18,898,341.42	2.40%	\$107,271.70
Savings-NSWP Funded Replace (2)	Five Star	\$905,580.71	2.103%	\$4,688.41	\$680,213.24	2.22%	\$3,501.19
Savings-Improvement Bonds(3)	Rabobank	\$29,255.93	0.05%	\$3.69	\$29,255.00	0.08%	\$6.02
Savings-Performance Bonds(3)	Five Star	\$18,732.30	2.103%	\$104.23	n/a	n/a	n/a
Savings-Performance Bonds(3)	Five Star	Account Closed-funds returned	n/a	n/a	\$204,331.02	2.22%	\$1,085.49
Savings-Improvement Bond(3)	Five Star	Account Closed-funds returned	n/a	n/a	\$1,168,112.40	2.22%	\$2,512.40

- (1) Analyzed Account
- (2) Nipomo Supplemental Water (NSWP) Funded Replacement Fund
- (3) Held in Trust – to be returned to developer upon completion of project
- n/a Not applicable

RECOMMENDATION

After Board consideration and public comment, it is recommended that your Honorable Board accept the quarterly report and direct staff to file the Report with District Auditor.

ATTACHMENTS

None